



**MESA USA
NATIONAL ENGINEERING DESIGN
COMPETITION**

**2011-2012
Wind Energy Challenge
CALIFORNIA ADDENDUM**

With the exception of the following, all the specifications in the document will be followed.

Rule 18: Teams **WILL** consider the cost of shipment of device to the local events. Teams **MUST** design their device to be disassembled for shipment in a large suitcase(s).

Project Labeling – WEC device, technical paper and academic display must be clearly labeled with student(s)' names, school and MESA Center.

A 25 point penalty will deducted from total score if either of the above are not properly labeled.

All other testing rules will still apply.

To preserve the integrity and the spirit of the competitions, judges of the technical paper and performance device of the Wind Energy Challenge may ask questions of any student team competitors pertaining to the drafting of their technical paper or the building of their device to validate the authenticity of their work. Failure to validate the work turned in may result in zero points for technical paper or zero points for device performance.



**MESA USA
NATIONAL ENGINEERING DESIGN COMPETITION
2011-2012**

Wind Energy Challenge

Contents

Overview

In order to maximize each team’s experience during this event, it is important to properly execute all aspects of the testing process and event administration. Although each MESA state may elect to present this event in different format(s), the MESA USA host site and the corresponding National Event Planning Committee will be required to adhere to the processes outlined below. Please note that the following processes not only outline the event but also the roles and responsibilities of student team members and advisors.

MESA USA Code of Sportsmanship

During the course of this event, MESA students, staff, advisors and supporting family members will be expected to act in a professional and courteous manner at all times. All judges’ decisions are final. Staff, advisors and parents shall not engage judges during the event.

Competition Overview	2
Device Performance	
- Objective.....	3
- Materials	3
- General Rules	3
- Test Configurations and Equipment	3
- Energy Source – Fan Specifications	5
- Electrical Load – Electrical Power and Wind Direction Task	5
- Task Details	5
- Construction and Repair	6
- Safety	6
- Inspection, Impound and Operation	6
- Measurement Equipment	7
- Electrical Power Measurement	7
- Wind Direction Platform	8
- Assigning Scores to Performance	9
Technical Paper	11
Academic Display	14
Oral Presentation	16
Scoring Criteria	
- Inspection and Performance Datasheet.....	17
- Technical Paper Criteria	18
- Academic Display Criteria	19
- Oral Presentation Criteria	20
Resource Materials	
- Reference Format & Examples.....	21
- Scale Drawing Sample.....	23
- Activity Feedback Form	24

MESA USA
NATIONAL ENGINEERING DESIGN COMPETITION
WIND ENERGY CHALLENGE
2011-2012



Competition Overview

MESA USA presents its national engineering design competition specifications for the 2011-2012 year. The Wind Energy Challenge event involves the transfer of energy from the wind source to the defined tasks. **The maximum amount of energy available to complete the tasks will be limited to that provided by the defined commercial fan and the task time constraints.** High school and middle school teams selected to participate at the national event will compete in the four components below:

- 1 **Performance** – Teams will research, design, build, test and compete with a windmill device designed to capture and use the available wind energy to complete the tasks. The performance of the devices will be judged in the following tasks:
 - a) Mechanical Power: greatest mechanical power generated raising a mass 75 cm.
 - b) Wind to Vehicle Kinetic Energy Transfer: greatest average kinetic energy achieved by the team’s vehicle using average speed and fixed mass over the track distance.
 - c) Electrical Power & Wind Direction Response: greatest average power output from the defined generator/electrical load during a 60 degree change in wind direction.
 - d) Design Efficiency: greatest ratio of device performance score to device mass.Middle school teams will compete in tasks a) and b). High school teams will compete in all three tasks.
- 2 **Technical Paper** – Teams will submit a 5-15 page technical paper that details the design, development, experimentation and understanding of their device.
- 3 **Academic Display** – Teams will present the findings of the above-described research in display format. The display should include items such as data (e.g., charts and graphs), photographs, drawings, other ideas, and necessary written explanations.
- 4 **Oral Presentation** – Teams will make an oral presentation based on investigation, experimentation, design, testing, and experiences related to their device. This presentation will be delivered to a panel of judges. After the presentation, teams will be asked questions by the judges.

Each team competing at the state and national level must consist of 2-4 students who are active members of a MESA center program in a MESA USA state. Individual states should encourage their respective teams to participate in all performance components at the statewide level. Individual states will determine the dates and location of their respective events.

The first place middle and high school teams from State events will travel to the national competition. These teams must compete in all tasks listed above. This event is scheduled to occur **June 21-23, 2012** hosted by Washington MESA. Feedback and comments are welcomed; please see the attached *Activity Feedback Form*.

Scoring Summary

Final team rankings will be based on the total score derived by adding all of the task scores.

Device Performance	150 points
Device Efficiency	50 points
Technical Paper	100 points
Academic Display	100 points
Oral Presentation	100 points
Total Points	500 points

Automated Event Scoring Software is available

sites.google.com/site/MESAUSAWEC



Objective

Students will build a Windmill that meets the criteria outlined in the rules and is designed to perform the following tasks:

- | | |
|--|--|
| <p style="text-align: center;">Middle School</p> <p>(1) Mechanical Power:
 <u>greatest</u> mechanical power generated raising a mass 75 cm. (2 trials)</p> <p>(2) Wind-to-Vehicle Kinetic Energy Transfer:
 <u>greatest</u> average kinetic energy achieved by the defined vehicle using average speed over the track distance. (2 trials)</p> | <p style="text-align: center;">High School</p> <p>(1) Mechanical Power:
 <u>greatest</u> mechanical power generated raising a mass 75 cm. (2 trials)</p> <p>(2) Wind-to-Vehicle Kinetic Energy Transfer:
 <u>greatest</u> average kinetic energy achieved by the defined vehicle using average speed over the track distance. (2 trials)</p> <p>(3) Electrical Power & Wind Direction Response:
 <u>greatest</u> average power output from the defined generator/electrical load during a 60 degree change in wind direction. (2 trials)</p> |
|--|--|

Design Efficiency – greatest ratio of performance score to device mass

Materials

- Hazardous materials may not be used in the construction or operation of the device, including but not limited to lead.
- All other materials to build the device are legal and optional

Rules

General Rules

1. Teams must design, build and operate their own windmill device. This device will include all parts necessary to capture the wind energy and transfer it to the defined tasks. It may include multiple fan/turbine assemblies.
2. The device must be solely powered by the wind energy available from the defined commercial fan.
3. All designs that conform to the energy rules will be allowed to participate. All teams should carefully review design configuration to ensure that no additional energy is applied to the tasks.
4. Once performance competition begins, student teams may not have contact with non-competitors. Student teams are solely responsible for interaction with judges and addressing problems with their devices.

Test Configurations and Equipment

5. Fan, Device and Working Area: (Fig. 1)
 - a. A six foot table will be used. Approximate dimensions of 30"x72"x29".
 - b. All parts of the windmill device must remain behind a line 50 centimeters from the end of the table.
 - c. The Device Area shown is intended as a platform for the devices.
 - d. The device may extend over the table edges to the sides and into the Working Area to complete the tasks.
 - e. Devices may be taped to the table or floor surfaces.
 - f. Teams may not touch their device once a task trial has begun.
 - g. Teams will be allowed 2 minutes to configure their device before each trial.

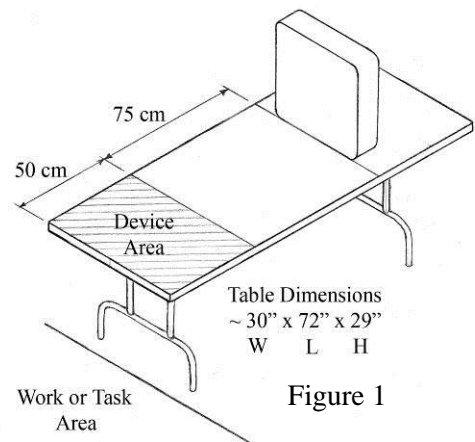

Figure 1



Test Configurations and Equipment – continued

6. Mechanical Power – Raising a Mass (Figure 2)
- Fan speed will be set to high.
 - Judge will use outlet strip to start the box fan-wind source and start the timer.
 - Judge will stop timer when entire mass is above 75 cm, and record time.
 - Judge will use outlet strip to stop box fan-wind source.
 - Judges will weigh the detachable object and record the mass.
 - Objects failing to reach 75 cm receive zero mass for that trial.
 - Repeat procedure for 2nd trial.

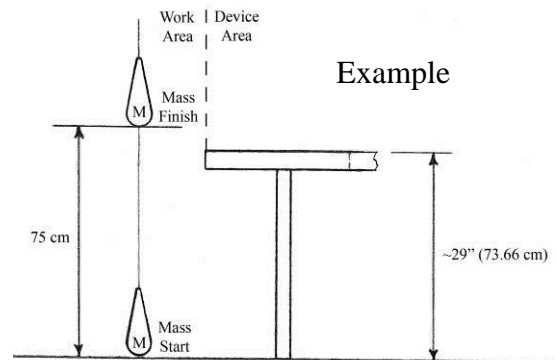

Figure 2

7. Wind-to-Vehicle (Figure 3)
- The fan speed will be set to High.
 - Teams will place the entire vehicle behind the “Start Line”.
 - Teams will design their device to move the vehicle from behind the Start Line” to the “Finish Line” as shown in Figure 3.
 - Judges will use outlet strip to start box fan-wind source and start the timer.
 - Judges will stop the timer when any part of the vehicle crosses the “Finish Line” within the boundary.
 - Vehicles failing to reach the “Finish Line” or leaving the track boundary during a trial will receive zero speed for that trial.
 - Repeat procedure for 2nd trial.

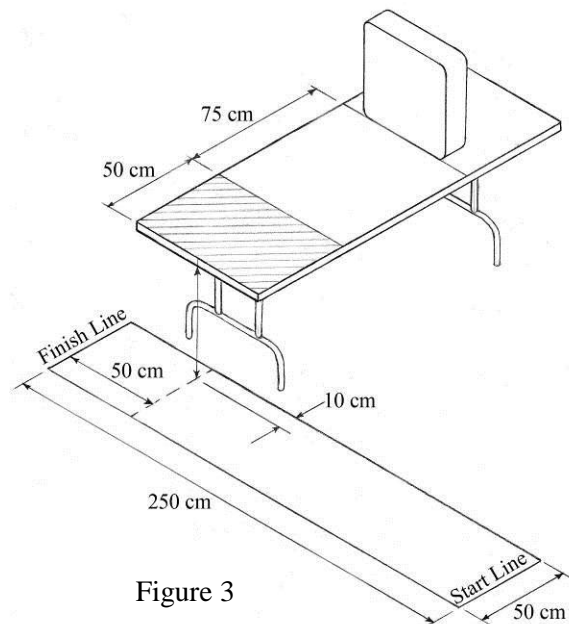

Figure 3

8. Electrical Power and Wind Direction Response (Figure 4)
- Student teams are required to use the specified generator to deliver electricity to the Electrical Load.
 - Fan speed will be set to High.
 - Fan motion will begin in Position #1 and rotate clockwise to Position #2.
 - Judge will simultaneously start the box fan-wind source, and the Stopwatch timer.
 - Starting at 10 seconds the box fan – wind source will be incrementally slid from left-to-right at approximately 10 degrees per 10 second.
 - Judge will record the Average Power delivered to the load between 10 and 70 seconds.
 - Repeat procedure for 2nd trial.

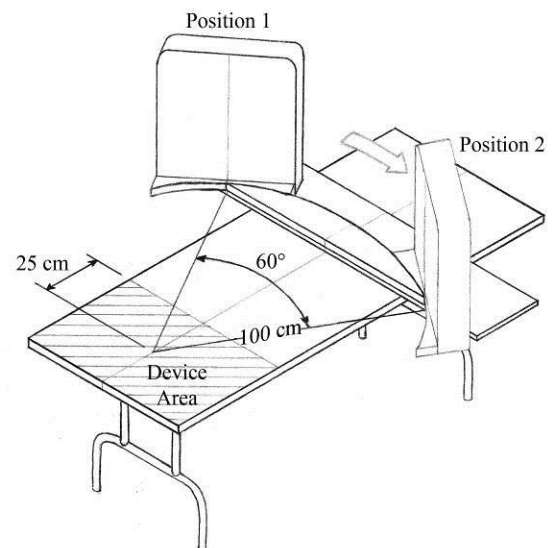

Figure 4



Test Configurations and Equipment - continued

Energy Source - Fan

9. Box Fan: Lasko Model 3733_– 20” 3-speed box fan or equivalent. These are 5-blade units that produce the following approximate wind speeds across their cross-sections when on the high setting:

Average Wind Speed (meters/second)		
Lasko	3733	2.60 @ 75cm

10. No part of the windmill device may be placed farther than **50** centimeters from the end of the table.
 11. An outlet strip will be used as the on/off switch for the fan, allowing desired fan speed to be set.

Electrical Load – Electrical Power and Wind Direction Task

12. Generator:

KidWind –
 Wind Turbine Generator, SKU H0002 (formerly
 SKU KWM001A or KWM001B) - SKU
 numbers are not on the Generators!!

13. Resistor & Base:

Radioshack –
 10 Ohm Carbon-Film Resistors (5-Pack),
 Catalog #: 271-013 or 271-1301 and
 2-Position Dual-Row Barrier Strips, Catalog
 274-656

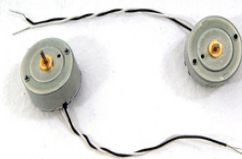

KWM100A



H0002



Task Details -

14. Mechanical Power – Raising a mass
- The teams will provide all materials necessary to complete the task, including detachable object(s) to be raised during this task.
 - The teams will select the mass and shape for the objects to be raised.
 - The shape and volume of the object(s) and windmill device design must allow the objects to be raised from contact with the ground to a point completely above the target height of 75 centimeters.
 - The object’s mass and the time taken to lift the object will determine the power achieved (mJ/s).
 - Teams will be allowed 2 minutes for setup of their device and mass for each attempt.
 - The mass must be raised above the table in 1 minute or less.
 - Two attempts will be recorded and the best performance is used in scoring.
15. Wind-to-Vehicle Kinetic Energy Transfer
- The team must provide all materials to complete the task, including their vehicle.
 - The device must accelerate their vehicle from behind the “Start Line” to the “Finish Line”.
 - The vehicle must have a mass of at least 200 grams.
 - Teams will be allowed 2 minutes for setup of their device for each attempt.
 - The vehicle must cross the finish line in 1 minute or less.
 - The vehicle must remain in contact with the floor throughout the trial from start to finish.
 - The vehicle mass and speed will be used to determine the kinetic energy of the vehicle (J).
 - Two attempts will be recorded; the best performance will be used in scoring.
16. HIGH SCHOOL ONLY – Electrical Power and response to change in Wind Direction
- The team must configure their device to use the defined generator to deliver the resulting electrical power.
 - The generator must be visible or accessible for inspection.



**2011-2012 MESA USA
National Engineering Design Competition
Wind Energy Challenge (WEC)
Device Performance
150 points**

16. (continued) HIGH SCHOOL ONLY – Electrical Power and response to change in Wind Direction
 - c. The team must have the generator wires arranged to allow for judge to connect Electrical Load and Power Measurement Equipment.
 - d. The device must respond to an incremental change of 10 degrees every 10 seconds.
 - e. Average Power measurement will be taken between 10 and 70 seconds from start of fan.
 - f. The Electrical Power measurement method will use Vernier equipment and Logger Pro software to monitor average power delivered to the load resistor during each trial. Each state, region or classroom program may use the alternative method during preparation.
 - g. Two attempts will be recorded; the best performance will be used in scoring.
17. Design Efficiency:
 - a. The device mass will be measured as a part of the device inspection. All parts used to complete the tasks will be included except vehicle mass, lifted masses and tape used to secure device during performance.
 - b. The Total Performance score from the Mechanical Power, Wind to Vehicle & Electrical Power tasks will be divided by the device mass in kilograms to determine Device Efficiency in points per kilogram.

Construction and Repair

18. Teams should consider the cost of shipment of device to the local events. It is recommended that teams design their device to be disassembled for shipment in a large suitcase(s).
19. Repairs are allowed, replacement parts and materials only, and all repairs must be done in the impound area under supervision of a judge. The addition of new or alternate parts not previously included is NOT allowed.

Safety

20. Standard safety practices shall be observed.
21. Use of eyeglasses or protective eye wear is required.
22. Students must operate their device in a safe manner. The device may only be activated when directed by the judges. Teams using UNSAFE PROCEDURES may have trials disqualified at the discretion of the judges.
23. The device must not pose a danger to students, officials, spectators or cause damage to the host facility, as determined by the judges.

Inspection, Impound and Operation

24. The trial order for performance events will be randomly selected.
25. Device inspection will take place prior to being impounded for the performance events. Inspection will include demonstration of device operation for all tasks to the judges.
26. Devices must be in testing condition prior to device inspection. If devices are disqualified during inspection check, design changes will not be allowed. Only devices passing inspection will be allowed to participate in the performance tasks.
27. All repair materials to be used during the competition must be impounded with the device. Devices will be released for trials but will remain impounded between tasks.
28. Each device must be ready for competition when called or forfeit that trial.
29. After teams arrive at task station, Judges will direct them to setup for the task.
30. Trial setup is limited to 2 minutes for each trial.
31. The team member responsible for operation of the device will indicate to the judge that the device is in the “ready-to-operate” position.
32. Students may not touch or interfere with the device once a task trial has begun.
33. If during operation a device is found to violate rules those trials will be disqualified.
34. Designs which prevent correct measurement of average power or kinetic energy will be disallowed.



Measurement Equipment

Raising a Mass		Wind to Vehicle	
<ul style="list-style-type: none"> • Meter stick • Stopwatch or video analysis • Postal Scale (grams) 		<ul style="list-style-type: none"> • Meter stick • Stopwatch or video analysis • Postal Scale (grams) 	
Electrical Power & Wind Direction			
Required	Vernier equipment (stand alone)	Vernier equipment (PC option)	
<ul style="list-style-type: none"> • 10-ohm Resistor 1/8 or 1/4 watt • 2 Row Barrier Strip • 2 Alligator clip leads 	<ul style="list-style-type: none"> • Labquest • Differential Voltage Probe (DVP-BTA) 	<ul style="list-style-type: none"> • Logger Pro Software • Differential Voltage Probe (DVP-BTA) • GoLink! (GO-LINK) 	

Electrical Power Measurement: Vernier Equipment Setup Details

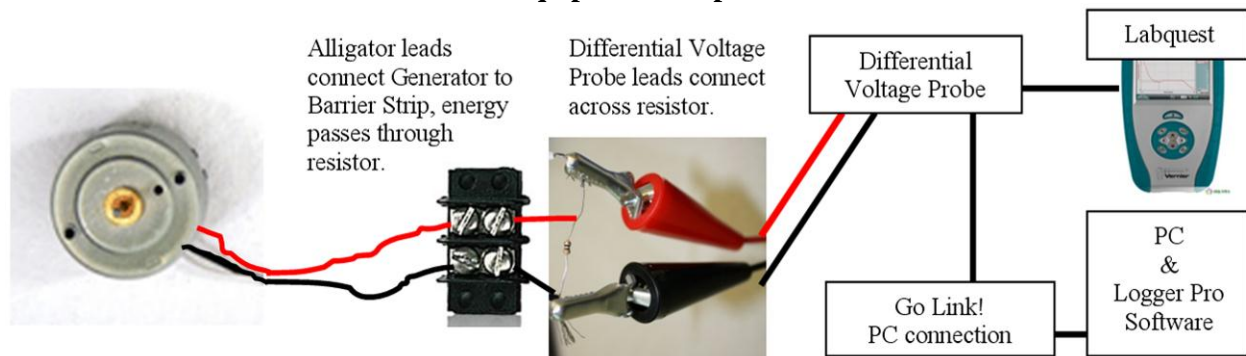

Both the Labquest and Logger Pro options allow the user to capture a graph of the power calculated from the voltage output and the value of the resistor (10-ohms) versus time. They also allow the user to determine the Average Power between times, 10 and 70 seconds for this application. (<http://www.vernier.com/>)

Alternative Method: Averaging the calculated power at multiple positions during the trail. It is recommended that measurements be taken at 10, 40 and 70 seconds. Multiplying the voltage and current readings for each measurement determines the power. Averaging of the three readings determines the team score. The circuit is arranged for one multi-meter to measure current (mA) and the other voltage (V).

- Generator provided by team and connected to their device with label showing
- Alligator clip leads will be used to attach Electrical Load and meters to generator

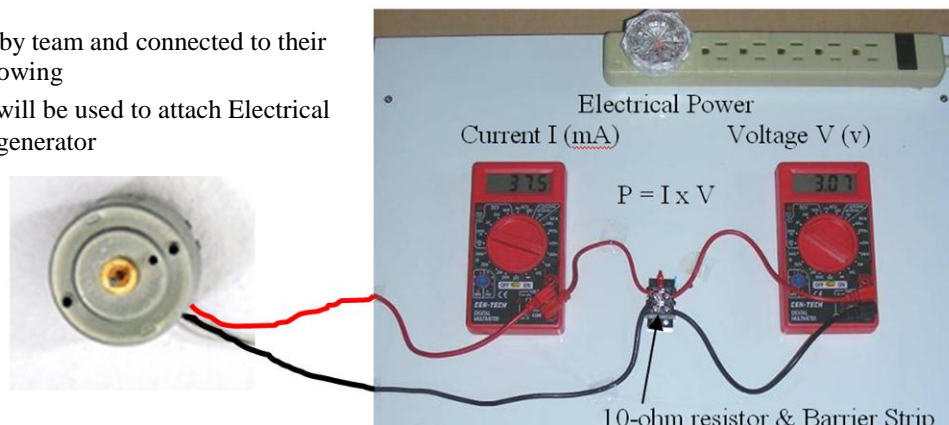





Wind Direction Platform

Supplies:

- Main Platform – 1 x 12 (3/4"x11") x 60"
- Main Arc – 1 x 6 (3/4"x5 1/2") x 40"
- Fan Contour Arc – 1 x 2 (3/4"x2") x 20"
- Small hinges (optional)
- Screws – 1 1/2" sheetrock screws

Instructions

1. The Main Platform remains the same.
2. The Main Arc requires a 100 cm radius arc be cut. This maintains the wind direction toward the Device Area center. Remove the hatched area shown. 
3. Align the Main Arc with Main Platform as shown in photo below and secure with screws.
4. Optionally, the final product may be cut in half and hinged on the top surface as shown in photo below.
5. The Fan Contour Arc is attached to the box fan base and also maintains the wind direction toward the Device Area center. Remove the hatched area shown. 
6. Remove screws from front of box fan; Align holes on Fan Contour Arc and pre-drill. Assemble Fan Contour Arc to box fan as shown in photo.

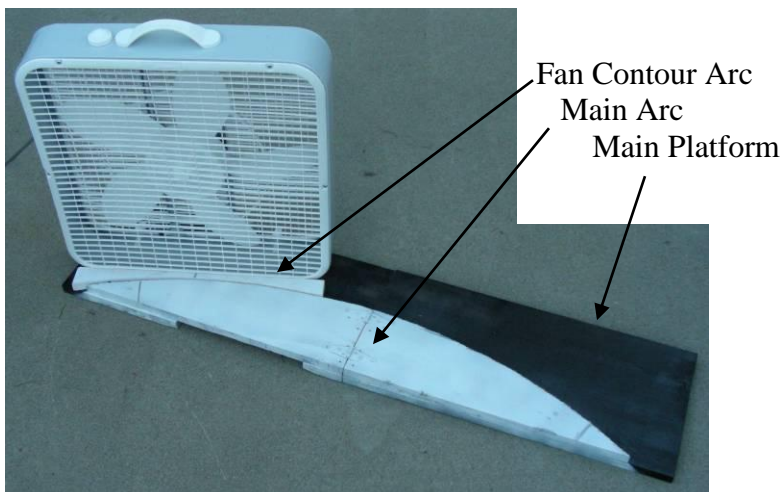
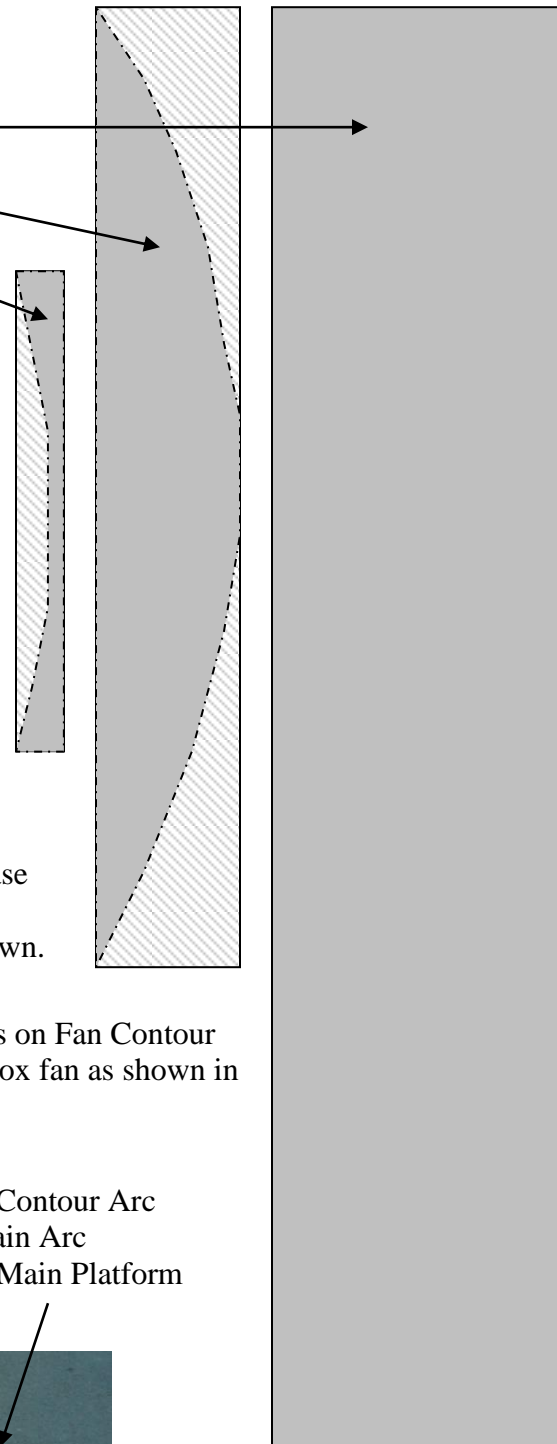



Assigning Points to Performance

1. The Total Performance Score will be determined by the sum of the points earned in each task.
2. Scores for each task equal the ratio of each device’s performance relative to the winning device’s performance on that task. Those scores are weighted according to the maximum points for each task:

Middle School Tasks: 75 points each
High School Tasks: 50 points each
3. Ties are allowed in each task

Mechanical Power – Raising a mass

1. Team Power Score (P_{tm}) =
 (Trial mass[grams] / Trial time) x (9.8 m/s²) x (0.75 m) [units: mJ/s]
2. Task Winner = Greatest team power score (P_{wm}) receives maximum points (75 or 50).
3. Task Points = Team Power (P_{tm}) divided by (P_{wm}), times max points or

$$\text{Task Points} = \frac{P_{tm}}{P_{wm}} \times 75 \quad \text{or} \quad \frac{P_{tm}}{P_{wm}} \times 50$$

Task Winner Winning Power (P_{wm}) = <div style="text-align: right;">156 mJ/s</div>	<u>Example</u> Team 5 Trial 1: mass=144g, time=7.25s Trial 2: mass=160g, time=10.16s Team Power (P_{tm}) = 145.9 mJ/s	Team 5 Points Middle School Score = (145.9/156.0) x 75 = 70.18 pts High School Score = (145.9/156.0) x 50 = 46.76 pts
---	--	---

Wind-to-Vehicle Kinetic Energy Transfer Task (Middle and High School)

1. High School Team Kinetic Energy (KE_t) =
 = ½ x (mass of vehicle[grams]) x (speed of vehicle)² [units: mJ]
 - mass of vehicle = as measured (grams)
 - speed of vehicle = Distance (2.5 meters) / Team Time (seconds)
2. Task winner (KE_w) = Greatest kinetic energy achieved by a vehicle.
3. Task Points = Team kinetic energy (KE_t) divided by (KE_w), times max points or

$$\text{Task Points} = \frac{KE_t}{KE_w} \times 75 \quad \text{or} \quad \frac{KE_t}{KE_w} \times 50$$

Task Winner – Best Trial Winning Speed & Mass = 2.5m / 9.54 s = 0.262 m/s = 200 grams Winning Energy (KE_w) = 6.87 mJ	<u>Example</u> Team 5 – Best Trial Best Speed & Mass = 2.5m / 13.26 s = 0.188 m/s = 200 grams Best Kinetic Energy (KE_t) = 3.55 mJ	Team 5 - Points Middle School Score = 3.55/6.87 x 75 = 38.75 pts High School Score = 3.55/6.87 x 50 = 25.84 pts
---	--	---



Assigning Points to Performance - continued

Electrical Power and Change in Wind Direction (High School)

1. High School Team Power (P_t)

Vernier Equipment (Labquest or PC/Logger Pro) Method:

= Average Power determined by graphing and averaging the delivered power between 10 and 70 seconds, in millijoules/sec or milliwatts (mW).

- Average (P_t) = Direct Measurement

Alternative Method:

= Average of Resistor Power measured at three times (10, 40 & 70 seconds) in millijoules/sec or milliwatts (mW).

- Power (P) = Voltage (volts) x Current (milliamps)

- Average (P_t) = $(P_{10} + P_{40} + P_{70})/3$

2. Task winner (P_w) = Greatest Average Power delivered to the load resistor.

3. Task Points = Team Power (P_t) divided by (P_w), times 50 points

$$\text{Task Points} = \frac{P_t}{P_w} \times 50$$

Task Winner – Best Trial	<u>Example</u>	
Winning Power (P_w) = 31.17 mW	Team 5 Team Power (P_t) = 27.63 mW	Team 5 - Points High School = $(27.63)/(31.17) \times 50 = 44.31$ pts

Total Performance Score:

1. Middle School Performance Score

= Mechanical Power + Wind to Vehicle

2. High School Performance Score

= Mechanical Power + Wind to Vehicle + Electrical Power & Wind Direction

Design Efficiency Score:

1. Design Efficiency (DE) =

Total Performance Score divided by the designed device mass (M_d)

2. Device mass is measured in kilograms, excludes vehicle mass, lifted masses and tape used to secure the device.

3. Design Winner =

Highest Design Efficiency (DE_w) receives 50 pts

4. Design Score =

Team Performance Efficiency (DE_t) divided by (DE_w) times 50 pts

$$\text{Design Score} = \frac{DE_t}{DE_w} \times 50$$

<u>Example</u>
Design Efficiency Score:
Winning Design Efficiency (DE_w) based on:
Team Performance Score = 147.65 pts
Team Device Mass = 4.32 kg
Winning $DE_w = 147.65 / 4.32 = 34.18$ pts/kg
Team 5 Design Efficiency (DE_t) based on:
Team 5 Performance Score = 133.9 pts
Team 5 Device mass = 5.73 kg
Team 5 $DE_t = 133.9 / 5.73 = 23.35$ pts/kg
Team 5 DE Score = $(23.35/34.18) \times 50 = 34.14$ pts



Objective

To clearly document their engineering design process, MESA students participating in the MESA USA National Engineering Design Competition will write a technical paper regarding the principles, design, and performance of their device.

Length

The paper should not be less than five pages or more than fifteen pages in length (excluding the title page and appendix). Thorough but concise papers are encouraged.

Electronic Format

Teams are required to save the document in Portable Document Format (PDF) or Microsoft Word format prior to submission. Teams shall also ensure the submitted final product can be read using Adobe Reader (8.0 or newer) or Microsoft Word (2003 or newer) and matches their original document.

Authorship

The authors must be members of the student team participating in the competition. The paper must be the original work of the authors. If professional assistance was needed for information or writing assistance, their names should be included in the references.

Deadline

The technical paper must be submitted via e-mail to Washington MESA on or before 5:00 pm local time on **Tuesday, June 15, 2012**. The papers will be judged and scored prior to the National Competition. Papers shall be e-mailed to: Washington MESA, Head Judge at WAMESA@uw.edu.

Written Presentation

The paper should be typed, double-spaced, and have a cover sheet. Graphics should be computer generated. The font used should be **Times New Roman** and the font size should be **12**. A one-inch margin is required on all sides. Readability will help your paper achieve a higher score in the judging.

The paper should include the following:

- A. Title Page - not included in the page count
- B. Abstract
- C. Table of Contents
- D. Introduction
- E. Discussion
- F. Conclusions
- G. Recommendations
- H. References or bibliography
- I. Acknowledgments
- J. Appendices (Optional) - not included in the page count

Title Page

Title, Authors, State, School and Date need to be included

Abstract

This section is a brief synopsis of your project, 200-250 words. It is the most important part of your paper, stating the purpose of the report and its most important features, the main conclusions and recommendations. It should be written in informative, non-technical terms and be interesting so that the reader is drawn to read further.



Table of Contents

Table of contents should correctly identify each required component of the paper.

Introduction

This is the narrative that prepares readers for the discussion that follows. It provides background for the reader before introducing any technical data. It is broken down into three sections that average one to two paragraphs each:

- Purpose: why the project was initiated and why the report was compiled (e.g., to solve a problem, to evaluate or introduce a new concept, etc.)
- Scope: defines the parameters of your report; outlines methods of investigation and any limiting factors
- Background Information: presents facts the reader should know, conditions or events prior to the project, details of previous reports

Discussion

This is the longest section of the paper. It presents and discusses all evidence (facts, arguments, data, tables, charts, graphs, etc. are referred to and explained here but should be located in the appendix).

1. Summarize the teams' device development, including a general description of design research, design selection and modifications made to satisfy event rules and task objectives.
2. Discuss physical phenomena related to the device. (e.g. Teams are encouraged to examine and report on potential and kinetic energy, work, aerodynamics, drag, velocity, force acceleration, mechanical advantage and other factors influencing the performance of their device. Newton's laws of motion may also be addressed in describing the movement of the device using terms such as action/reaction, mass, momentum, inertia, etc.)
3. Use of advanced concepts, techniques, algorithms or other materials that would not normally be included in middle or high school subjects must be explained. The paper must show how the team's research and work led to their selection and use. Appendices may be used for this purpose.
4. Experimental procedures and test setup (pictures or diagram)
5. Data reduction, analysis tools and models
6. Data (Table, graphs, charts, pictures, diagrams)
7. Results

The discussion section should be imaginative enough to hold the reader's interest and organized logically. Three common ways to organize are shown below:

- Chronological development: present information in order of occurrence, usually the easiest way to organize
- Subject development: present information by subjects, grouped in a predetermined order
- Concept development: arrange information as a series of ideas that reveal the reasoning process used to reach the conclusions; requires more careful organization but allows more creativity and persuasion. Writers should anticipate reader reactions. If presenting a controversial concept, establish a strong case before discussing it in detail. If presenting a popular or familiar concept, briefly and simply establish your case.



Conclusion

In this section, state the major inferences that can be drawn from the discussion. Be sure the evidence was presented in the discussion section. No new evidence should appear in this section.

Recommendations

This section is used to indicate further work to be done or to indicate the best solution when several solutions have been presented. Write recommendations, in strong definitive terms using first person and active verbs.

References

All sources that are consulted should be properly cited according to the APA format. See Resource Materials section for example references and additional information.

Acknowledgments

This section should be used to recognize individuals or groups who have provided support and guidance throughout the design process.

Appendices (optional)

This section contains, in detail, supporting data, charts, tables, photographs, test results, etc. that were referred to earlier in the paper.

Criteria for Evaluation and Scoring

Shown below are the main areas that will be considered in the evaluation of the technical paper. See the Scoring Materials section for specific details and overall criteria.

- Discussion (40 pts)
- Abstract (20 pts)
- Introduction (15 pts)
- Conclusion & Recommendations (15 pts)
- Written Presentation (10 pts)



Objective

The purpose of the display is to provide a visual representation of the engineering design process used to develop the team's device. Teams will present their device and relevant aspects of the design project from the technical paper. The focus of the display should only be the actual device presented for performance.

Materials Provided

- 30" x 72" x 29" (cafeteria style) table

Form, Key Features & Organization

- The maximum display area is equivalent to two 36" x 48" tri-fold presentation boards placed side-by-side on the table.
- The entire display must be on the table and not extend beyond the table top. Displays may be taped to the table for stability.
- Electronic media are not allowed.
- The team state, school and members should be prominently displayed.
- Except for the tri-fold presentation board no element of previous year's display may be reused. All elements must be original for this year.

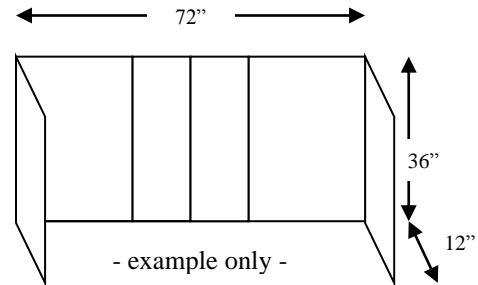

Required Elements

- **Abstract** – A brief synopsis of the project, 200-250 words
 - State the purpose of the technical paper and its most important features, the main conclusions and recommendations
 - It should be written in informative, non-technical terms and be interesting to the reader
- **Data and Technical Explanation** – Teams will show their exploration and share explanations of their device and the scientific and engineering ideas involved in the project
 - **Teams should include key physics concepts as well as engineering challenges and solutions**
 - Teams should incorporate text, photographs, drawings, images, tables, charts, graphs, models etc. that share information relevant to the overall project
 - Teams may identify the features of the device using a system of labels or pointers
 - Include modifications made to your device to ensure that it is a top contender.
 - Teams are also encouraged to examine potential and kinetic energy, mechanical advantage, friction, work, Newton's Laws of Motion, and any other pertinent topics.
- **Scaled Drawing** – A three-view drawing depicting the actual device designed and built.
 - See Resource Materials section for example scaled drawing format
 - Front, side, and top views should be included, see sample page 28
 - All parts of the device should be labeled
 - 3" x 5" Title Card including drawing title, brief description, date completed, and scale used
 - Photographs are not permitted in place of a scaled drawing
 - Scaled drawing may be drawn by hand or computer generated, both methods scored equally.
 - Maximum paper size shall be 11"x17"



**2011-2012 MESA USA
National Engineering Design Competition
Wind Energy Challenge (WEC)
Academic Display
100 points**

- **Cost and Labor Summary** – A table summarizing essential cost and labor details of the project.
 - Minimum size – 8 ½” x 11” sheet of paper
 - Required Content:
 - Materials – description, source, purchased or donated, actual or estimated cost. Include an estimated total cost.
 - Labor – estimated student hours applied to complete project elements; Device, Technical Paper, Academic Display & Oral Presentation.

Criteria for Evaluation and Scoring

Shown below are the main areas that will be considered in the evaluation of the academic display. See the scoring materials section for specific details and overall criteria.

- Technical Explanations & Data Presentation (40 pts)
- Scaled Drawing & Cost-Labor Summary (30 pts)
- Form, Key Features & Organization (10 pts)
- Abstract (10 pts)
- Creativity (10 pts)



Objective

The purpose of the presentation is to provide information about the engineering design project to a panel of judges. Students will organize and deliver a focused, coherent presentation that provides a overview of the development of their design including research, experimentation and conclusions. The judges should understand the speech and become engaged in the presentation. Speeches must be the original work of the team.

Materials Provided

- table
- easel board
- PC computer with Microsoft PowerPoint 2003 or newer
- LCD projector and screen

Required Elements

- **The processes and procedures used in design development.**
- **Discussion of related physical phenomena.**
- **Observations and data related to any experiments, testing or research conducted.**
- **Conclusions derived from the engineering design process.**

Rules

1. Each team will have a maximum of 2 minutes to set-up for their presentations.
2. Presentation attire will be the official MESA USA National Engineering Design Competition t-shirts. A 5-point deduction will be applied for teams not wearing the official t-shirts.
3. Props, models, charts, graphs or other visual aids should be used.
4. Electronic presentations using Microsoft PowerPoint are allowed but are limited to text and images. Other electronic materials not allowed. Teams should not rely heavily on electronic media.
5. Teams are expected to bring their presentation on either a CD or USB flash drive.
6. Each team may speak for a maximum of 10 minutes. A 5-point deduction will be applied for presentations exceeding 10 minutes. Judges will expect to hear directly from all teams members.
7. Teams may invite audience members at their discretion to attend the presentation. Once the presentation begins, audience interruptions will not be permitted.
8. Teams are expected to do research. They may interview and quote experts, associates, or use quotations from written sources. They may provide examples, and/or use illustrations, facts, and figures.
9. All key concepts should be well understood by the team. The use of advanced concepts, techniques, algorithms or other materials that would not normally be included in middle or high school subjects must be explained. Teams must explain how their research and work led to their selection and use.
10. Teams will be randomly selected to determine speaking order.
11. Students must give their presentations in the order drawn. No exceptions or late arrivals are allowed.
12. Judges will provide time signals at 3 minutes, 1 minute, 30 seconds, and 5 seconds before time is called.
13. Once the presentation is complete, the judges will conduct a 5 minute question and answer period. These questions will be brief and to the point, and solely to ascertain student knowledge of the project.

Criteria for Evaluation

Shown below are the main areas that will be considered in the evaluation of the Oral Presentation. See the Scoring Materials section for specific details and overall criteria.

- Technical Content (40 pts)
- Overall Presentation (30 pts)
- Oral & Visual Performance (20 pts)
- Question Responses (10 pts)



Inspection and Performance Datasheet

MESA Center: _____

MESA School – Level (MS/HS): _____

Advisor/Teacher: _____

Student Team: _____

Inspection

Sole Energy Source Box Fan ONLY Y / N
 Vehicle Mass (200 grams or more)..... Y / N
 Generator: KidWind.org – Wind Turbine Generator Y / N
 Electrical Load: 10-ohm resistor provided by event host Y / N

Device Mass: All parts excluding vehicle mass, lifted masses & tape... _____ kg

Performance

Mechanical Power

Trial 1	Trial 2
_____ mass (grams)	_____ mass (grams)
Start: _____ Stop _____ (sec)	Start: _____ Stop _____ (sec)

Wind-to-Vehicle Kinetic Energy Transfer

Trial 1:	Trial 2:
_____ vehicle mass (grams)	_____ vehicle mass (grams)
Start: _____ Stop _____ (sec)	Start: _____ Stop _____ (sec)

Electrical Power & Wind Direction (high school only)

Trial 1:	Trial 2:
<u>Vernier/Logger Pro Method</u>	<u>Vernier/Logger Pro Method</u>
Average Power: _____ (mW)	Average Power: _____ (mW)
-----	-----
3-Sample Method	3-Sample Method
10-second measurements	10-second measurements
Position 1 Voltage: _____ (volts)	Position 1 Voltage: _____ (volts)
Position 1 Current: _____ (mA)	Position 1 Current: _____ (mA)
40-second measurements	40-second measurements
Position 2 Voltage: _____ (volts)	Position 2 Voltage: _____ (volts)
Position 2 Current: _____ (mA)	Position 2 Current: _____ (mA)
70-second measurements	70-second measurements
Position 3 Voltage: _____ (volts)	Position 3 Voltage: _____ (volts)
Position 3 Current: _____ (mA)	Position 3 Current: _____ (mA)



TECHNICAL PAPER SCORING CRITERIA

2011-2012 MESA USA National Engineering Design Competition

TEAM:

SCHOOL:

LEVEL: MS or HS

Discussion a-Physical Phenomena, b-Experiment Procedures, c-Data & Analysis, d-Tables & Charts e-Results	Abstract a-Length b-Purpose & Key Features c-Conclusions & Rec. d-Non-technical e-Informative & Interesting	Introduction a-Purpose b-Scope c-Background Information	Conclusion & Recommendations a-Inferences & Evidence b-Further Work & Reasoning	Written Presentation a-Length b-Font c-Spacing d-Key Sections e-Supporting Sections f-Grammar,Spelling, etc.
Level 4 - 4 points each a. Very thorough discussion of Physics, Math and/or Engineering concepts, including advance concepts if used. b. Very complete description of experimental/testing procedures including diagrams or pictures c. Thorough description of data analysis, any subsequent calculations performed or other operations to explore the data. d. Highly relevant tables, graphs, charts, etc. e. Very clear explanation of results w/graphics	Level 4 - 4 points each a. Length: 200-250 words b. Very clearly restates Purpose & Key Features of report c. Very clearly restates Conclusions and Recommendations of report d. Written very clearly in non-technical terms e. Engages and informs the reader	Level 4 - 4 points each a. Purpose: Very clearly states why project undertaken AND why report developed b. Scope: A very thorough description of parameters, methods, limiting factors & technical terms c. Background: Share key facts, conditions, events prior to project AND previous work on this topic	Level 4 - 4 points each a. Conclusion: Inferences follow very logically from discussion evidence No new material included b. Recommendations: Further work/best solution well identified Written in first person w/ active verbs	Level 4 - 4 points each a. Length: 5-15 pages, cover, title page and appendices not included, 1" margins b. Font: 12, Times New Roman c. Spacing: double spaced d. All Key Sections included: Title page, Abstract, Contents, Introduction, Discussion, Conclusion, Recommendations e. All Supporting Sections included: References, Acknowledgments, Appendix f. Proper grammar, spelling and sentence structure used throughout the paper.
Level 3 - 3 points each a. Effective discussion of key concepts, including advanced concepts if used. b. Effective description of procedures including diagrams or pictures c. Good description of data analysis d. Tables, graphs, charts, etc. useful to report e. Good explanation of results w/graphics	Level 3 - 3 points each a. Length: 150-199 or 251-300 words b. Good restatement of Purpose/Key Features c. Good restatement of Conclusions & Recommendations d. Well written, but includes some technical terms e. Modestly engages and informs reader	Level 3 - 3 points each a. Effective/complete statement of purpose b. Effective statement of scope, 1 or 2 items appear missing or overlooked c. Effective and complete background details, 1 or 2 items appear missing or overlooked	Level 3 - 3 points each a. Conclusion: Inferences follow loosely from discussion evidence No new material included b. Recommendations: Further work/best solution not well identified	Level 3 - 3 points each a. Length: 5-15 pages, 1" margins b. Font: Some inconsistency throughout c. Spacing: Some inconsistency throughout d. 1 Key Section not identified or missing e. 1 Supporting Section not identified or missing f. Some errors in grammar, spelling, etc.
Level 2 - 2 points each a. Limited discussion of key concepts, including advanced concepts if used. b. Limited description of procedures, with few diagrams or pictures c. Data analysis poorly described or not used d. Graphics not well used to support report e. Very little discussion of results, no graphics	Level 2 - 2 points each a. Length: 100-149 or 301-350 words b. Poor restatement of Purpose or Key Features c. Poor restatement of Conclusion or Recommendations d. Many technical terms e. Uninteresting to reader	Level 2 - 2 points each a. Incomplete statement of purpose for project and report b. Incomplete statement of scope, multiple items missing or overlooked c. Limited background information included	Level 2 - 2 points each a. Conclusion: Inferences follow poorly from discussion, evidence not clear Some new material included b. Recommendations: Further work/best solution not well identified	Level 2 - 2 points each a. Length: <5 or >15 pages, >1" margins b. Font: very inconsistent throughout c. Spacing: very inconsistent throughout d. 2-3 Key Sections not identified or missing e. 2 Supporting Sections not identified or missing f. Several errors in grammar, spelling, etc.
Level 1 - 1 point each a. Little or no discussion of key concepts, including advanced concepts if used. b. Little or no description procedures c. Data analysis not included d. Graphics do not support report e. No discussion of finding/results	Level 1 - 1 point each a. Length: <100 or >350 words b. Purpose or Key Features not included c. Conclusion or Recommendations not included d. Unclear to the reader e. Does not engage reader	Level 1 - 1 point each a. Very poor or no statement of purpose for project b. Very poor or no statement of scope, very little information included c. Very poor or no background provided, very little or no information provided	Level 1 - 1 point each a. Conclusion: Inferences do not follow from discussion or evidence present new material included b. Recommendations: Further work/best solution not identified	Level 1 - 1 point each a. Length: <5 or >15 pages, >1" margins b. Font: incorrect throughout or not typed c. Spacing: incorrect throughout d. Most Key Sections missing e. Most Supporting Sections missing f. Poor attention to grammar, spelling, etc
Points Score $16/20 \times 40=32$	Points Score $/20 \times 20=$	Points Score $/12 \times 15=$	Points Score $/8 \times 15=$	Points Score $/24 \times 10=$
Judge			Total	
Judge Feedback:				



ORAL PRESENTATION SCORING CRITERIA

2011-2012 MESA USA National Engineering Design Competition

TEAM:

SCHOOL:

LEVEL: MS or HS

Technical Content a-Physical Phenomena b-Process & Procedures c-Data and Explanations d-Observations e-Conclusions	Overall Presentation a-Introduction b-Topic c-Flow d-Content e-Engagement of the Audience	Oral & Visual Performance a-Student Voice b-Presence c-Eye Contact d-Collaboration e-Visual Material	Question Responses a-Accurate & Specific b-Depth of Knowledge
Level 4 - 4 points each a. Several examples of physical phenomena of topic well explained & understood, including advanced concepts if used b. Process & Procedures of development well described c. Data explanations very clear and tied to topic d. Observations follow direct from experiments, testing or research e. Conclusions well thought out and accurate	Level 4 - 4 points each a. Creative introduction of team members & responsibilities b. Very clear description of presentation topic c. Flow – moved very smoothly from point-to-point d. Content – stayed very focused on the topic e. Unique activities & discussion captured and maintained audience & judge attention very well	Level 4 - 4 points each a. ALL voices heard and understood throughout room b. Student demeanor & appearance well suited for event c. Eye contact is distributed throughout room d. ALL student share equally in presentation e. ALL visual aids contribute audience understanding	Level 4 - 4 points each a. ALL questions answered specifically and accurately b. ALL responses show thorough knowledge of project
Level 3 - 3 points each a. Some examples of physical phenomena of topic explained & understood, including advanced concepts if used b. Some of the design process well described c. Data presented/explained well, not related to topic d. Observations follow from experiences, but not clearly from experiments, testing or research e. Conclusions lack detail or include a misconception	Level 3 - 3 points each a. Includes a prepared introduction of team members b. Includes effective topic introduction c. Flow – 1 or 2 poor transitions between points d. Content – strays little from topic unnecessarily e. Activities and discussion engage audience & judges	Level 3 - 3 points each a. Few situations with poor voice projection b. 1 or 2 lapses in student demeanor & appearance c. Few situations of poor use of eye contact d. Some lapses in student collaboration & teamwork e. Most visual aids contribute effectively	Level 3 – 3 points each a. 1 or 2 responses inaccurate or lack detail b. Some responses lack thorough knowledge of project
Level 2 - 2 points each a. Very few examples of physical phenomena of topic, including advanced concepts if used b. Very little of design process described c. Unclear data, poorly explained, not related to topic d. Observations do not follow from experiences, limited evidence of experiments, testing or research e. Conclusions unrelated to technical content or includes misconception	Level 2 - 2 points each a. Team introduction poorly done b. Presentation topic not clearly stated c. Flow – several poor transitions between points d. Content – strays unnecessarily from topic repeatedly e. Some activities do not engage audience & judges	Level 2 - 2 points each a. Repeated lapses in voice projection b. Student demeanor & appearance questionable for event c. Quality eye contact sporadic or not used by all members d. One student dominant or excluded from presentation e. Visual aids unclear or cannot be clearly seen by audience	Level 2 – 2 points each a. 3-4 responses inaccurate or lack detail b. Knowledge of all project elements limited
Level 1 - 1 point each a. No discussion of physical phenomena related to topic, including advanced concepts if used b. No discussion of design process c. No data collection or analysis presented d. No Observations made, or do not follow from activities e. No conclusions or recommendations provided	Level 1 - 1 point each a. Lacks team introduction b. Lacks description of presentation topic c. Flow – erratic, no clear point-to-point discussion d. Content – strays from specific topic e. Does not capture audience/judge attention	Level 1 - 1 point each a. Voices very difficult to hear and understand b. Appearance not appropriate for presentation c. Very poor eye contact, focused on one person or none d. Presentation dominated by one student e. Visual material very difficult to see and understand	Level 1 – 1 point each a. Fails to answer questions or ask for clarification b. Students unprepared to respond to questions
Points Score $/20 \times 40 =$	Points Score $/20 \times 30 =$	Points Score $/20 \times 20 =$	Points Score $/8 \times 10 =$
Judge	Attire 5 point deduction MESA USA event shirts required	Time 5 point deduction for over time limit	Total

Sample Questions

- What do you think would happen if ...?
- Describe a situation when you resolved a design problem.
- Please elaborate on your description or explanation of...?
- What were the most difficult parts of the paper, performance tasks or academic display? And why?

Judge Feedback:



**2011-2012 MESA USA
National Engineering Design Competition
Wind Energy Challenge (WEC)
Resource Materials
Reference Format & Examples**

Reference Format:

Citing Sources in Technical Writing

If you use books, journals, magazines, and websites to get ideas for your research, it helps you write a better paper. You can quote other people or quote the research that someone else did, and it will support your ideas and theories. When you use another person's idea, words, or research, you need to cite the source.

For every book, website, conversation, interview, article, etc. that you read, listen to, or look at, you need to write down the following information:

- The **author** of the information (who wrote or spoke the material?)
- The **title** of the text, website, or article
- The **date** that the material was first published (for a conversation or interview, use the date that the discussion occurred; for a website, record the date you accessed the website--the date you first looked at the page)
- For journal and magazine articles, the **title of periodical and position** in a series (e.g. *Journal Name, Volume 5, Issue 49*) and the **pages** where the information is located
- The **publication information** (i.e. city, state, & publisher name)
- For websites, the **URL** address (e.g. <http://www.google.com>)

If you're reading an article or a small piece that's part of a bigger book, then you also need:

- The **title of the larger collection** (if you're reading an encyclopedia article, then this means the name of the encyclopedia)
- The **editor** of the larger collection (someone that collected all the articles together, whether or not they wrote anything themselves)

At the end of your paper, you will need a **Reference** page. This page will include entries for all the sources that you used while writing your research paper. For papers in the field of Engineering, researchers often use a citation style developed by the American Psychological Association (APA). This style permits others who read your paper to find the original sources you used--websites, articles, books, etc.--and experience the original document. It includes all the information someone would need to find your source and it organizes the information in a style so that you don't need headings such as "Title," "Author," or "Date of Publication," because it is obvious from the order in which you present these things.

In APA style, books are cited this way:

An article in a periodical (e.g. a journal, magazine, or newspaper):

Style	Author, A. A., Author, B. B., & Author, C. C. (Date of Publication). Title of article. <i>Title of Periodical, volume number, pages.</i>
Example	Maldonado, J., & Bierly, H. (2002, August 20). Vehicle test trials across the country. <i>Scientific American, 159, 28-31.</i>

A non-periodical (e.g. book, report, brochure, or audiovisual media):

Style	Author, A. A. (Year of publication). <i>Title of work</i> . Location: Publisher.
Example	McNaughton, J. (2000). <i>Engineering Realities and Possibilities</i> . Chicago: University of Chicago Press.

An article in an internet periodical:

Style	Author, A. A., & Author, B. B. (Date of publication). Title of article. <i>Title of journal, volume number</i> (issue number if available). Retrieved month day, year, from http://web address .
Example	Estrada, S. & Williams, C. (2003, June 23). Perceiving the future of technology. <i>Engineering Today</i> , 15 (3). Retrieved June 28, 2003 from http://www.engtoday.org/15.3.html .

A motion picture or video tape:

Style	Producer, P. P. (Producer), & Director, D.D. (Director). (Date of publication). <i>Title of motion picture</i> [Motion picture]. Country of origin: Studio or distributor.
Example	Chavez, A. (Producer), & Walele, J. (Director). (1998). <i>Women Pioneers in Science</i> . [Motion Picture]. U.S.: Educational Films Inc.

Further Information

For more information about APA style, consult the *Publication Manual of the American Psychological Association* (5th edition) which can be found in most libraries. Also, consider looking at these web resources:

The APA style website
<http://www.apastyle.org>

The Online Writing Lab (OWL) at Purdue University
http://owl.english.purdue.edu/handouts/research/r_apa.html



2011-2012 MESA USA
National Engineering Design Competition
Wind Energy Challenge (WEC)
Resource Materials
Scale Drawing Sample

← Width – 17" – →

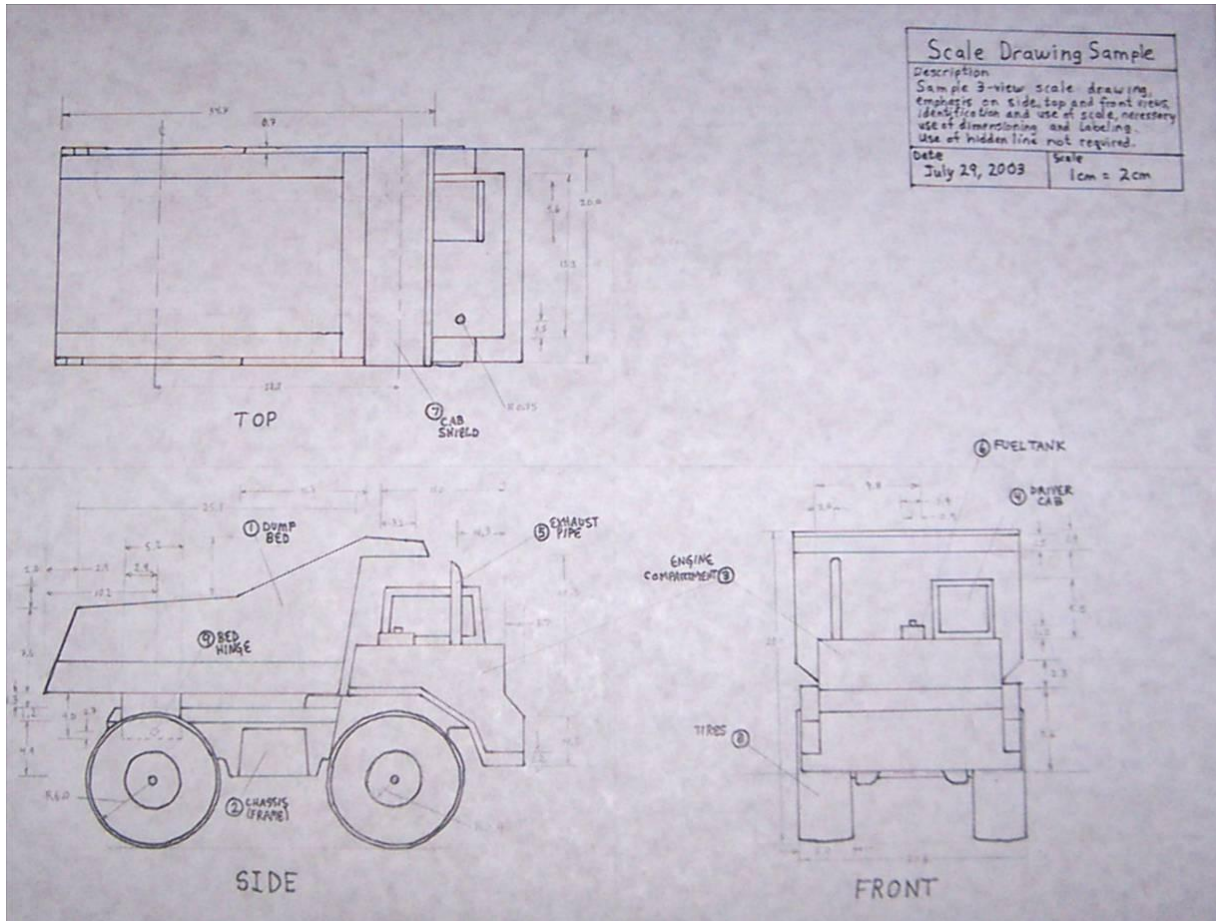

↑ Height – 11" ↓

