

MESA DAY CONTEST RULES 2011-2012



Balsawood Glider

| | |
|-----------------------------|--|
| LEVEL: | 9 th and 10 th Grade |
| TYPE OF CONTEST: | Team |
| COMPOSITION OF TEAM: | 1 - 2 students per team |
| NUMBER OF TEAMS: | 3 teams per Center |
| SPONSOR: | Alan Brown, UCSC Center MESA |

OVERVIEW: Students will design and build a glider made of balsawood, which will be launched outdoors using a hand-held catapult provided by the host center. The goal of the contest is to keep the glider aloft for the longest period of time.

MATERIALS: The following are the ONLY materials that may be used to build the glider.

- Balsawood
- Glue, any type
- Modeling Clay
- Paint, stickers, decals, markers and ink may be used as needed for decoration or for identification

RULES:

- 1) No ready-made kits are allowed. Each glider should be designed, constructed, launched and repaired by contestants.
- 2) There is no restriction on the size or weight of the glider.
- 3) Any glider that incorporates additional materials not mentioned above will be disqualified.
- 4) A 1:1 scale plan rendering should accompany the glider for evaluation. The rendering should include two drawings: an isometric view and a three-view drawing that includes the dimensions of the glider in metric units. The use of CAD is encouraged; however, points will not be deducted if the rendering is hand-drawn. The plan rendering should also state the names of the contestants, their school, and their MESA center.

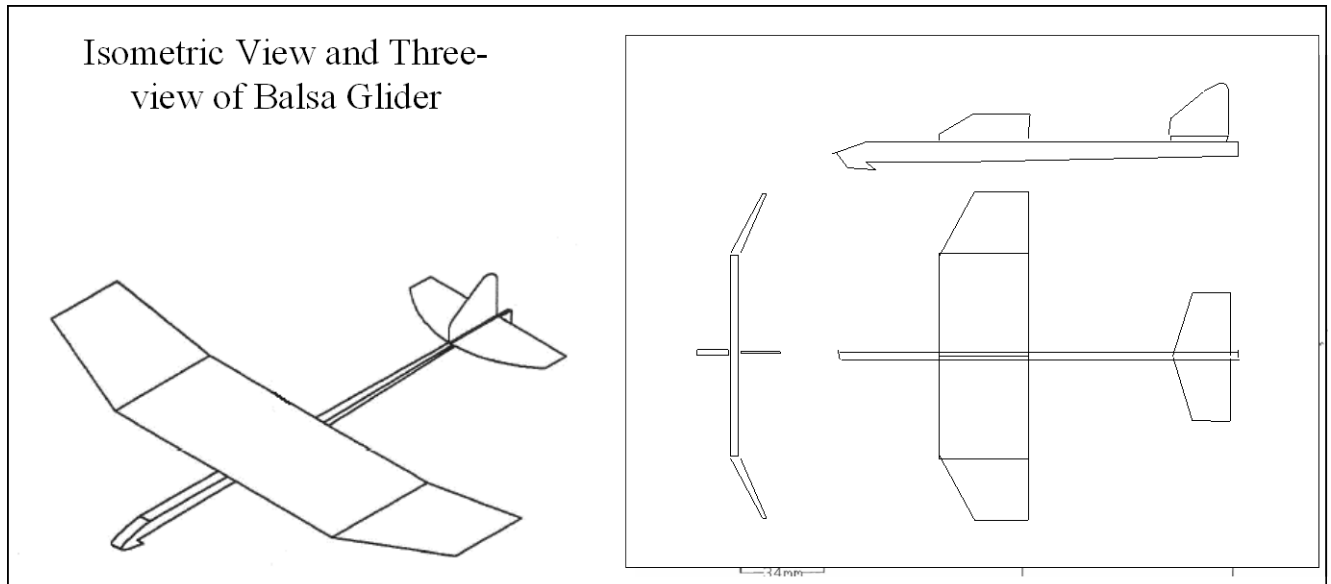

- 5) The glider should have a hook on the underside of the fuselage to permit launching with the catapult. Cutting a flush notch into the underside of the fuselage is NOT acceptable. (see diagram below). The hook need not be a separate item from the main fuselage.

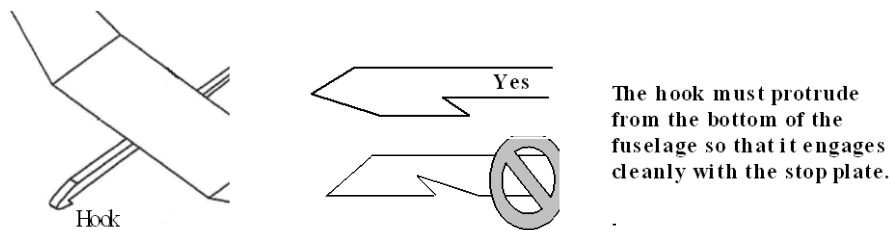

- 6) The contestant's name(s), school, and center should be clearly visible on the glider. They should be identified using a sharpie pen or equivalent. **Do not use a separate tie-on label, as this will be considered to be a part of the model when it is turned in for judging**. Failure to correctly identify the glider as noted will result in a 10% deduction from the final score as calculated in item 9 of 'Judging'. Two decals will be allowed up to two inches square each, but no material which could be construed as an extra surface finish.
- 7) The glider should be competition-ready when turned in for inspection at MESA Day. No modifications to the glider are allowed after the glider is submitted to the judges for inspection. The design drawing should be submitted for judging at the time the glider is inspected.
- 8) The gliders will be launched using a catapult provided by the host center. Catapults have the following specifications:

- Platform: One piece of wood 5mm x 45mm x 700mm
- Stop Plate: One piece of wood 6mm x 45mm x 350mm
- Handle: 20mm x 30mm x 150mm
- "T" Handle Support: 15mm x 15mm x 75mm (Two screws attach the handle support to the platform and the stop plate)

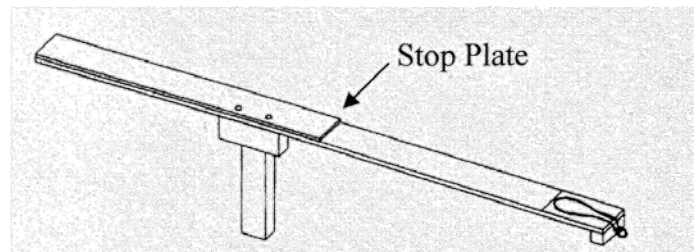

- Screw Eye Attachment Block: 15mm x 15mm x 45mm
 - Screw Eye
 - Rubber Band: Office Max # 32 or equivalent. The rubber bands will be kept in a sealed plastic bag. The band on the catapult will be replaced by a new one every five launches.
- 9) The glider is hooked to the rubber loop at the end of the catapult. The contestant pulls the glider back until the hook touches the wooden stop at the front of the stop plate on the catapult (see diagram on previous page). The launch angle and attitude of the catapult is determined by the contestant. Any launches made with the nose hook pulled beyond the stop plate will be counted as an unscored launch, thereby reducing the number of scored launches for the contestant.
 - 10) The release height of the glider shall not exceed six feet above ground level as measured by a stick held vertically next to the contestant during launch. Launches above six feet shall be counted as an unscored launch, thereby reducing the number of scored launches.
 - 11) The contestant releases the glider after being given the “OK” from the official timer. Timing starts as soon as the glider is released and stops when the glider hits the ground or comes to rest against any obstruction. The glider can be launched in any direction, starting from the prescribed launching area.
 - 12) Each glider is given three (3) launches. The winning glider is determined by the following formula: longest flight time + second longest flight time + plan rendering score
 - 13) Repairs are allowed between flights. However, no changes may be made to the basic design of the glider once the competition is under way. Repairs should be made by the contestants.

JUDGING:

- 1) Once an entry has been registered it may not be altered or repaired to meet technical inspection.
- 2) No part(s) of the glider may be removed or added after the specification check has occurred. No backup gliders will be allowed. No tools or materials will be supplied at MESA Day.
- 3) Each team will be allowed three non-consecutive launches. Each glider should be ready for competition when called. The glider should be launched within 30 seconds of being called or contestants will forfeit that launch. Three stopwatches will be used by three judges for timing flights. The flight time will be determined by taking the middle value of the three times.
- 4) The judges will determine where the launching site should be. They will ensure that there is sufficient space available that the gliders can circle and fly downwind without hitting obstructions. Typical dimensions might be a thirty meter radius circle, and eighty meters downwind.
- 5) Spectators should not be allowed within the flight area at anytime during the competition.
- 6) In the event of a tie, the glider with the longer single flight time will be the winner.
- 7) Times will be recorded to the nearest hundredth second.

These materials are for the internal use of MESA staff and teachers only and should not be forwarded or used outside of MESA.s

8) Scoring the rendered plans will be based on the following rubric:

| Isometric View | Three-View | Metric Measurements | Proper Labeling | Rendering Quality | Rating | Points (seconds) |
|----------------|------------|---------------------|-----------------|-------------------|-------------------|------------------|
| √ | √ | √ | √ | √ | Superior 5/5 | 2 |
| √ | √ | √ | √ | | Good 4/5 | 1 |
| √ | √ | √ | | | Adequate 3/5 | 0 |
| √ | √ | | | | Inadequate 2/5 | -1 |
| | | | | | NONE | -2 |

9) Overall scoring is determined from this formula:

longest flight time in seconds + second longest flight time in seconds + rendered plan score

AWARDS: Awards will be given for 1st, 2nd and 3rd place.

CHECKLIST:

- Glider made of balsa, glue and clay; no metal objects on/in glider
- Glider has projecting hook, not cut into fuselage
- Rendered plans have isometric and three-views; all metric measurements; 1:1 scale
- Glider and plans are properly labeled with names, school and MESA center
- Glider has no extra surface finish material